



The company performing R&D and production of all kind of microwave garnets, spinels, hexaferrites, absorbing ferrites, and microwave ceramics used in various components of broad spectrum of radio engineering facilities such as radar antennas, telecommunication complexes including mobile satellite stations, electronic countermeasure systems, high power nonreciprocal devices of particle accelerators, different contactless measuring/sensor instruments, the list can go on-and-on.

**FERRITE DOMEN Co.**

8, Chernigovskaya St.,
196084 St. Petersburg,
Russia

Phone +7 (812) 387 7187

Fax +7 (812) 388 3791

E-mail: info@domen.ru

www.ferrite-domen.com

Symbols

$4\pi M_s$	Saturation magnetization	Gauss
DH	FMR linewidth	Oe
ϵ'	Dielectric constant	
$tg\epsilon$	Dielectric loss tangent	
g_{eff}	Landé factor	
T_C	Curie temperature	°C
DH_k	Spin wave linewidth	Oe
H_C	Coercive force	Oe
B_r	Remanent flux density	Gauss
H_{Aeff}	Effective anizotropy field	Oe
r	Density	g/cm^3

Yttrium garnets

Pure Yttrium garnets are the basic ferromagnetic materials for the whole series of YIG - doped compositions, see example grade.

Material grade	$4\pi M_s$ G $\pm 5\%$	DH (-3dB) Oe	ec $\pm 5\%$	$tg d_e \cdot 10^4$	g_{eff} $\pm 3\%$	T_c oC nomin.	DH_k Oe nomin.
G-178	1780	≤ 45	15.1	≤ 2	2.00	280	1

YIG - Al doped

That series of microwave garnets is presented as the richest product mix by saturation magnetization values. They are most widely used in low power m-, dm-, and cm-wave devices.

Material grade	$4\pi M_s$ G	DH (-3dB) Oe	ec $\pm 5\%$	$tg d_e \cdot 10^4$	g_{eff} $\pm 3\%$	T_c oC nomin.	DH_k Oe nomin.
GA-150	1500 $\pm 5\%$	≤ 45	14.9	≤ 2	2.00	250	1
GA-140	1400 $\pm 5\%$	≤ 45	14.8	≤ 2	2.00	245	1
GA-120	1200 $\pm 5\%$	≤ 45	14.6	≤ 2	2.00	230	1
GA-110	1100 $\pm 5\%$	≤ 45	14.5	≤ 2	2.00	220	1
GA-100	1000 $\pm 5\%$	≤ 45	14.5	≤ 2	2.00	210	1
GA-90	900 $\pm 5\%$	≤ 45	14.4	≤ 2	2.00	200	1
GA-80	800 $\pm 5\%$	≤ 45	14.2	≤ 2	2.00	195	1
GA-65	650 $\pm 5\%$	≤ 45	14.2	≤ 2	2.00	175	1
GA-58	580 $\pm 5\%$	≤ 45	14.1	≤ 2	2.01	165	1
GA-48	480 $\pm 25G$	≤ 40	14.0	≤ 2	2.01	150	1
GA-40	400 $\pm 25G$	≤ 40	13.9	≤ 2	2.01	130	1.5
GA-32	320 $\pm 25G$	≤ 40	13.8	≤ 2	2.01	120	1.5
GA-20	200 $\pm 25G$	≤ 40	13.7	≤ 2	2.03	100	2

Saturation magnetization vs. Temperature Yttrium and YIG - Al doped garnets

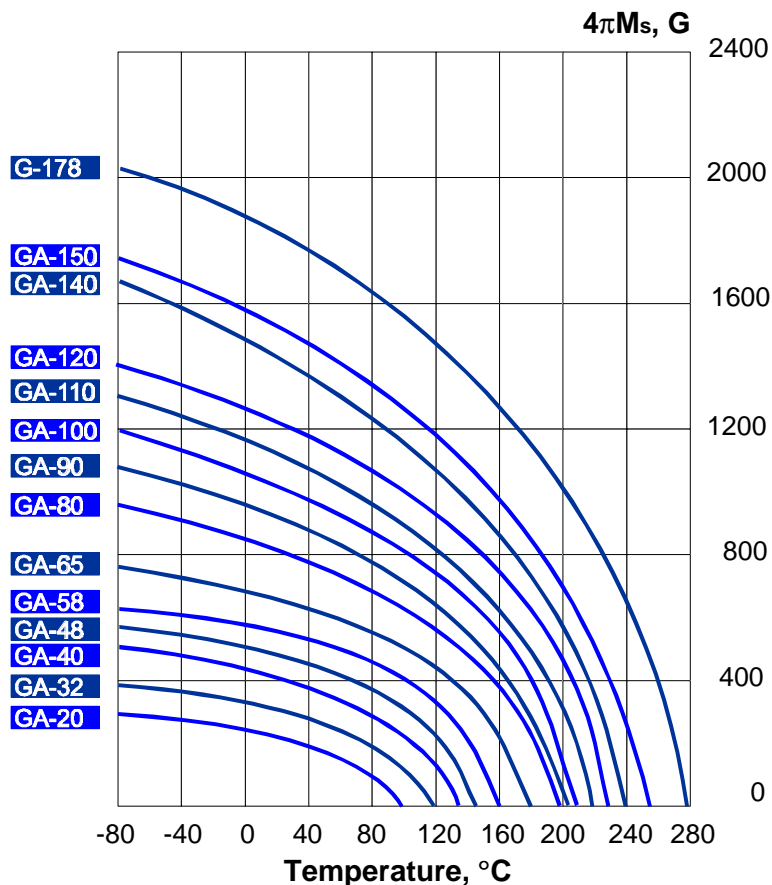

The garnets of this group feature the narrowest FMR linewidth of all YIG series. They are especially suitable for application in microwave devices (including cryogenic ones) having low losses and efficient in wide frequency and temperature ranges.

Material grade	$4\pi M_s$ G $\pm 5\%$	DH (-3dB) Oe	$e\epsilon'$ $\pm 5\%$	$tg d_e \cdot 10^4$	g_{eff} $\pm 3\%$	T_c °C nomin.	DH_k Oe nomin.
NG-190	1900	≤ 15	15.0	≤ 2	2.00	215	1
NG-160	1600	≤ 12	14.8	≤ 2	2.00	220	1
NG-120	1200	≤ 10	14.5	≤ 2	2.00	180	1
NG-100	1000	≤ 10	14.2	≤ 2	2.00	170	1
NG-80	800	≤ 10	14.1	≤ 2	2.00	160	1
NG-52	520	≤ 10	13.9	≤ 2	2.00	120	1

Saturation magnetization vs. temperature

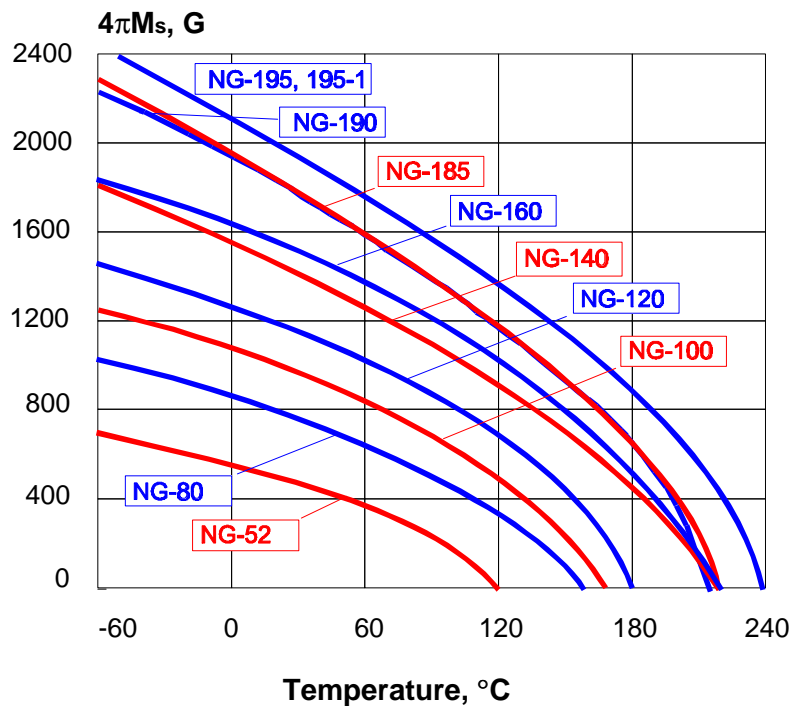

The prime features of these garnets are high temperature stability of their parameters, good squareness of hysteresis loop and raised threshold power. They find wide application in average and high power non-reciprocal as well as controlled microwave devices (phase shifters, switches, filter etc.).

Material grade	$4\pi M_s$ G $\pm 5\%$	DH (-3dB) Oe	ϵ_c $\pm 5\%$	$tg d_e \cdot 10^4$	g_{eff} $\pm 3\%$	T_c oC nomin	H_c Oe nomin	B_r G nomin	DH_k Oe nomin
GG-178	1780	≤ 42	15.0	≤ 2	2.00	280	0.55	1240	2
GG-160	1600	≤ 45	14.9	≤ 2	2.00	280	0.75	1120	4
GG-120	1200	≤ 75	15.2	≤ 2	2.01	280	0.60	820	8
GG-95	940	≤ 95	15.1	≤ 2	2.01	255	0.70	660	10
GG-80	800	≤ 85	14.7	≤ 2	2.01	240	0.55	525	9
GG-55	550	≤ 65	14.5	≤ 2	2.01	180	0.55	385	8
GG-50	490	≤ 200	14.5	≤ 2	2.03	205	0.65	325	21

Saturation magnetization vs. temperature

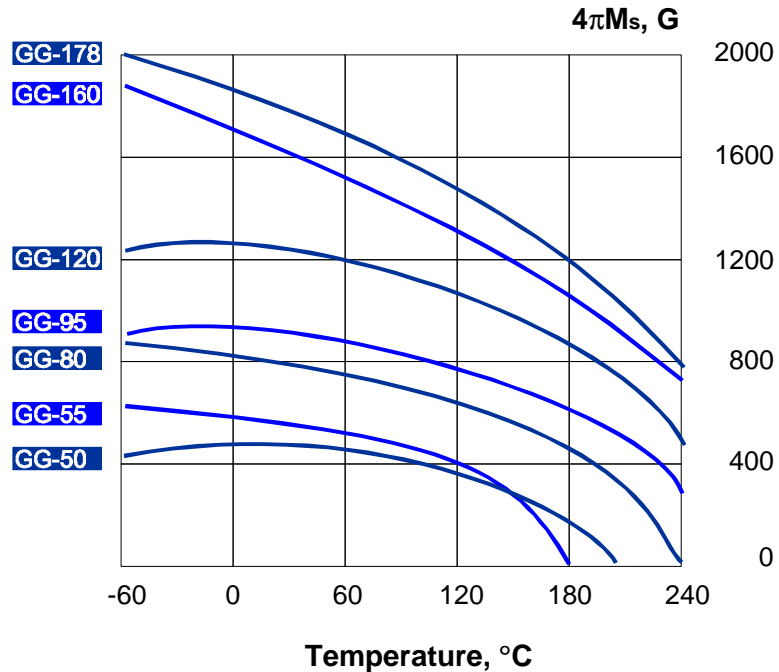

The garnets of this group have low losses with rather high thermal stability of saturation magnetization and good threshold characteristics. They were developed for use in non-reciprocal average power devices.

Material grade	$4\pi M_s$ G	DH (-3dB) Oe	$e\epsilon$ $\pm 5\%$	$tg d_e \cdot 10^4$	g_{eff} $\pm 3\%$	T_c °C nomin.	DH_k Oe nomin.
GI-138	1380 $\pm 5\%$	≤ 20	15.0	≤ 2	2.00	240	5
GI-130	1300 $\pm 5\%$	≤ 42	15.1	≤ 2	2.00	225	6
GI-122	1220 $\pm 5\%$	≤ 20	14.9	≤ 2	2.00	220	3
GI-120	1200 $\pm 5\%$	≤ 35	15.0	≤ 2	2.01	220	10
GI-115	1150 $\pm 5\%$	≤ 35	15.1	≤ 2	2.00	230	7
GI-85	850 $\pm 5\%$	≤ 55	15.0	≤ 2	2.01	210	10
GI-63	630 $\pm 5\%$	≤ 48	14.6	≤ 2	2.01	150	14
GI-45	450 $\pm 25\%$	≤ 48	14.5	≤ 2	2.02	135	13
GI-40	400 $\pm 25\%$	≤ 95	14.5	≤ 2	2.03	160	13

Saturation magnetization vs. temperature

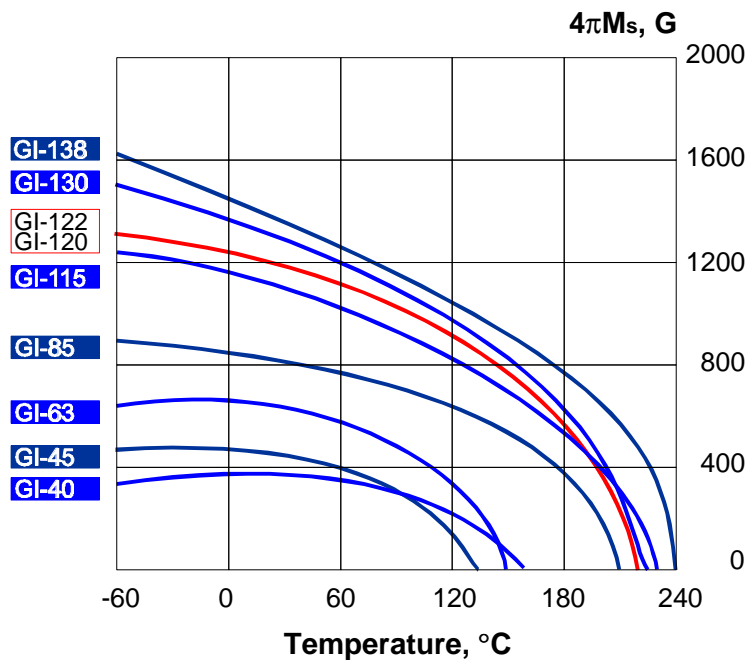

The garnets of this group feature extremely good threshold characteristics. They are used in devices which must operate at high peak power levels.

Material grade	$4\pi M_s$ G	DH (-3dB) Oe $\pm 20\%$	$e\epsilon$ $\pm 5\%$	$tg d_e \cdot 10^4$	g_{eff} $\pm 3\%$	T_c oC nomin.	DH_k Oe nomin.
GH 178	1780 $\pm 5\%$	25	15.1	≤ 2	1.99	280	3.5
GH 128	1280 $\pm 5\%$	60	15.1	≤ 2	2.00	225	16
GH 120	1200 $\pm 5\%$	100	15.0	≤ 2	2.01	275	15
GH 65	650 $\pm 5\%$	45	14.7	≤ 2	2.01	150	16
GH 47	470 $\pm 25\%$	45	14.5	≤ 2	2.00	130	19
GH 33	330 $\pm 25\%$	160	14.2	≤ 2	2.02	160	26

Saturation magnetization vs. temperature

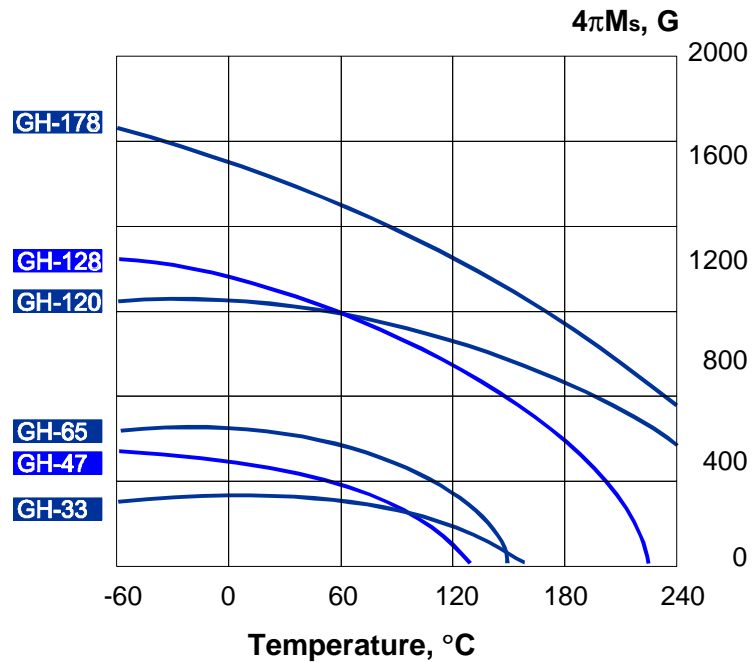

STANDARD FORM AND DIMENSIONS OF MICROWAVE FERRITE PARTS

Ferrite parts can be delivered both as fired or machined articles.

SHAPES

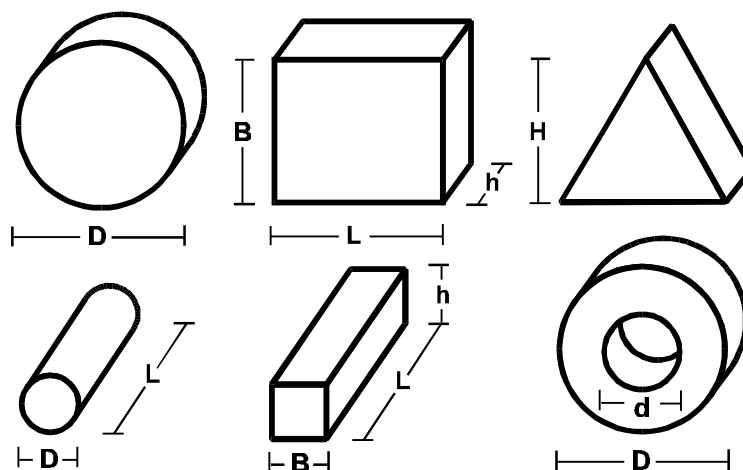

Parts as fired, dimensions (mm)

	Disks	Plates (square, rectangle, triangle)	Round and square cross-section rods	Rings
D	10...120		5...40	5...100
L		15...120	20...120	
B		5...60	5...30	
H		≤90		
h	3...10	3...10	5...15	2.5...15
d				2...70

Standard tolerances: $\pm (3...4)\%$

Machined parts are to be delivered in accordance with the Customer's drawings.

Standard tolerances: ± 0.02 mm

Standard finish: Ra 0.6 mm



FERRITE DOMEN Co.

8, Chernigovskaya St., 196084 St. Petersburg,
Russia

www.ferrite-domen.com

Phone: +7 (812) 387 7187

Fax: +7 (812) 388 3791

E-mail: info@domen.ru